

AUTO-LOCK TILTING QUICK HITCH



Compact in design, powerful and virtually maintenance free, the Gardner Engineering Auto-lock Tilting Quick Hitch incorporates a precision built actuator ensuring trouble free operation.

- ✓ Australian Made
- ✓ Hi tensile steel construction
- ✓ Compact design – improving machine performance
- ✓ Integral overload protection
- ✓ Fully guarded hoses
- ✓ Up to 180 degrees of tilt
- ✓ Actuator only has two moving parts and is 100% sealed
- ✓ Automatic dual lock
- ✓ Multicoupler design
- ✓ Fully compliant with current legislation and Australian standards



HKS ACTUATOR AT A GLANCE

- ✓ Slim structure
- ✓ Replaces cylinders
- ✓ Maintenance free
- ✓ Wide tilting range
- ✓ Simple assembly
- ✓ Screwed or welded version
- ✓ Perfectly protected against dirt

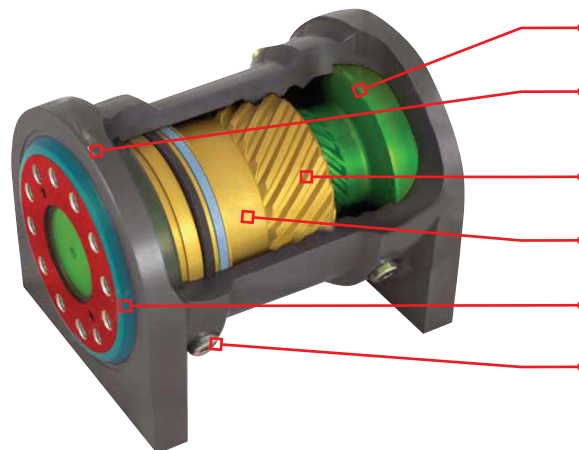

- Shaft with mounting flange and friction bearings all in one
- End flange with friction bearings, fastening thread and special deflector on both sides
- Ultimate precision manufacture of paired interleaving
- Surface-hardened piston with guiding element
- Actuator centring on both sides for optimum power distribution
- Surface-hardened and corrosion-resistant housing with screw or weld-type fastening on the feet

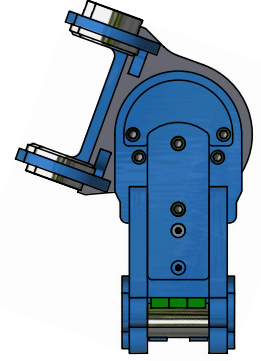
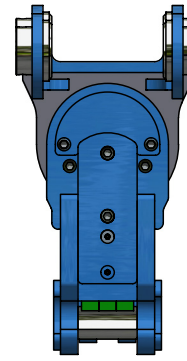
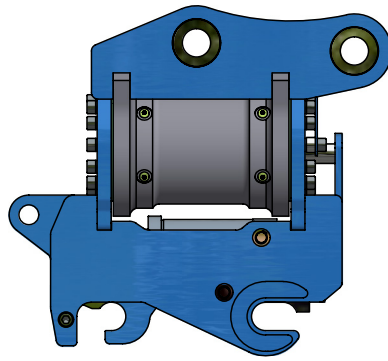
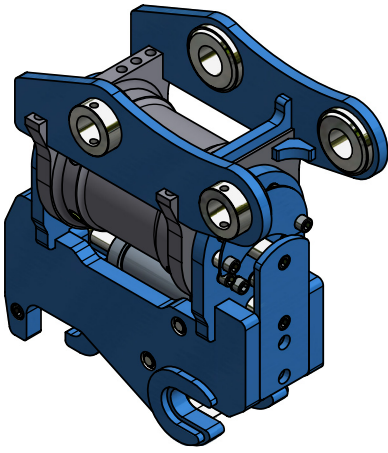

GARDNER ENGINEERING AUTO-LOCK TILTING QUICK HITCH

STRONGER • SAFER • MORE RELIABLE

PRODUCT RANGE

1 - 1.8 Tonne	BVC 100 – 180 Degrees
2 - 3.8 Tonne	BVC 115 – 180 Degrees
4 - 6.8 Tonne	BVC 130 – 180 Degrees
6 - 9 Tonne	BVC 160 – 180 Degrees
12 - 15 Tonne	BVE 240 – 140 Degrees
16 - 23 Tonne	BVE 250 – 140 Degrees
22 - 26 Tonne	BVE 260 – 140 Degrees
28 - 34 Tonne	BVE 290 – 140 Degrees

BUCKET WITH LINEAR CYLINDER

Minimum working width

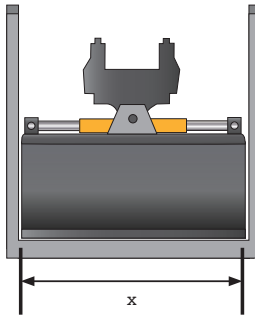

- ✗ Only suitable for Mud Buckets
- ✗ Damage to the cylinders caused by soil, stones and dirt
- ✗ Continuous re-lubrication and greasing of the cylinder bearing necessary
- ✗ Tilt head with bearing surfaces requiring lubrication, time-consuming assembly
- ✗ Over time, worn-out connection elements must be replaced

GARDNER ENGINEERING AUTO-LOCK TILT QUICK HITCH

Minimum working width

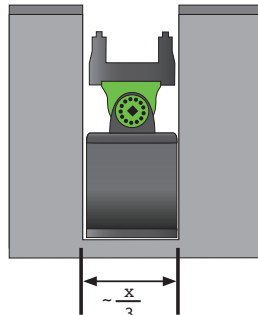

- ✓ Durable, robust, protected, powerful
- ✓ Greater accessibility thanks to greater tilt angle
- ✓ The lack of maintenance saves servicing costs
- ✓ Compact – fits all buckets and tools

Simplified representation

COMPARISON WITH STANDARD PRODUCTS

The Gardner Engineering Australia Auto-Locking Tilting Quick Hitch allows you to simply tilt all your attachments rather than having to move the entire machine, greatly improving the productivity and versatility of your machine resulting in better productivity and increased profits.

APPLICATIONS

Demolition, ditch cleaning, ripping landscaping, site development, road build, railway construction, forestry, bush cutting, mining the Gardner Engineering Australia Auto-Lock Tilting Quick Hitch is suitable for all.

SAFETY

Automatic Dual Locking System

WARRANTY

3 Years Structural Warranty
1 Year Actuator & Hyd Cylinder

COMPLIANCE

AS4772-2008 Fully compliant to Australian Standards and Workcover NSW Position Paper. Documentation for Maintenance Record provided.

GARDNER ENGINEERING AUSTRALIA
7 BABDOYLE STREET LOGANHOLME, QLD 4129

PHONE: (07) 3801 3855
EMAIL: sales@gardnerengineering.com.au



WWW.GARDNERENGINEERING.COM.AU